

This print-out should have 21 questions. Multiple-choice questions may continue on the next column or page – find all choices before answering.

001 10.0 points

Consider the half-reactions and the balanced equation for the cell reaction represented by the skeletal equation

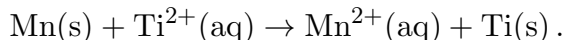

What is the proper cell diagram for this reaction?

1. $\text{Ti}^{2+}(\text{aq}) | \text{Ti(s)} || \text{Mn(s)} | \text{Mn}^{2+}(\text{aq})$
2. $\text{Mn(s)} | \text{Mn}^{2+}(\text{aq}) || \text{Ti}^{2+}(\text{aq}) | \text{Ti(s)}$
3. $\text{Mn}^{2+}(\text{aq}) | \text{Mn(s)} || \text{Ti(s)} | \text{Ti}^{2+}(\text{aq})$
4. $\text{Ti(s)} | \text{Ti}^{2+}(\text{aq}) || \text{Mn}^{2+}(\text{aq}) | \text{Mn(s)}$

002 10.0 points

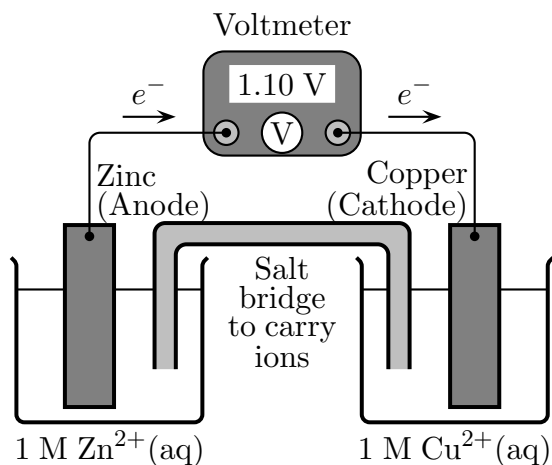

In this electrochemical cell, what is the reduction half reaction?

1. $\text{Zn}^{2+}(\text{aq}) + 2 e^{-} \rightarrow \text{Zn(s)}$
2. $\text{Cu}^{2+}(\text{aq}) + 2 e^{-} \rightarrow \text{Cu(s)}$
3. $\text{Cu(s)} \rightarrow \text{Cu}^{2+}(\text{aq}) + 2 e^{-}$
4. $\text{Zn(s)} \rightarrow \text{Zn}^{2+}(\text{aq}) + 2 e^{-}$

003 10.0 points

What is the standard cell potential of a battery made from the half reactions

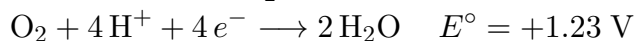

1. 2.46
2. 1.23
3. -1.23
4. -2.46

004 10.0 points

In a galvanic cell,

1. oxidation takes place at the cathode.
2. electrolytes are added to carry electrons between electrodes.
3. electrical energy is used to reverse spontaneous chemical reactions.
4. oxidation and reduction take place at the same time but at different electrodes.

005 10.0 points

Silver is plated on copper by immersing a piece of copper into a solution containing silver(I) ions. In the plating reaction, copper

1. is oxidized and is the oxidizing agent.
2. is reduced and is the reducing agent.
3. is reduced and is the oxidizing agent.
4. is oxidized and is the reducing agent.

006 10.0 points

What is the E° for the following electrochemical cell where Zn is the cathode?

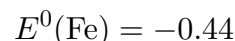
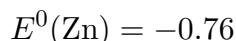

1. -1.20

2. -0.32 3. $+0.32$ 4. $+1.20$

007 10.0 pointsWhich of the metals in the list below will react with 1 M H_2SO_4 to produce hydrogen gas?

	E^0 (volts)
$\text{Na}^+ + 1 e^- \rightarrow \text{Na}$	-2.714
$\text{Cd}^{2+} + 2 e^- \rightarrow \text{Cd}$	-0.403
$\text{Pb}^{2+} + 2 e^- \rightarrow \text{Pb}$	-0.126
$\text{Cu}^{2+} + 2 e^- \rightarrow \text{Cu}$	$+0.337$

1. Na, Cd, and Pb only
2. Na, Cd, Pb, and Cu
3. Na and Cd only
4. some other combination than those listed
5. Na only

008 10.0 points

Consider the voltaic cell:

$\text{Pt} \text{Sn}^{2+} (0.10 \text{ M}), \text{Sn}^{4+} (0.0010 \text{ M})$	$ \text{Ag}^+ (0.010 \text{ M}) \text{Ag}$
$\text{Sn}^{4+} + 2 e^- \rightarrow \text{Sn}^{2+}$	$E^0 = +0.15 \text{ V}$
$\text{Ag}^+ + 1 e^- \rightarrow \text{Ag(s)}$	$E^0 = +0.80 \text{ V}$

The electrons flow in the external circuit from

1. Ag to Pt.
2. Ag to Sn^{4+} .
3. Sn^{2+} to Ag^+ .
4. Sn to Ag.
5. Pt to Ag.

009 10.0 pointsUsing the standard potential tables, what is the largest approximate E^0 value that can be achieved when two half cell reactions are

combined to form a battery?

1. -3 V 2. 6 V 3. -6 V 4. 3 V

010 10.0 points

Consider the cell

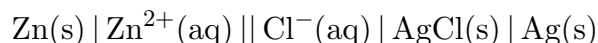
Calculate E° .

1. $+0.54 \text{ V}$
2. $+1.20 \text{ V}$
3. $+0.98 \text{ V}$
4. -0.54 V
5. -1.20 V

011 10.0 pointsWhich species will oxidize Cr^{2+} but not Mn^{2+} ?

1. Zn^{2+}
2. Pb^{4+}
3. V^{3+}
4. Fe^{2+}
5. O_3 in acidic medium

012 10.0 pointsIf the standard potentials for the couples $\text{Cu}^{2+} | \text{Cu}$, $\text{Ag}^+ | \text{Ag}$, and $\text{Fe}^{2+} | \text{Fe}$ are $+0.34$, $+0.80$, and -0.44 V , respectively, which is the strongest reducing agent?

1. Ag

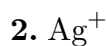

Using the redox couples to establish a voltaic cell, which reaction would be non-spontaneous?

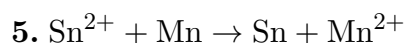
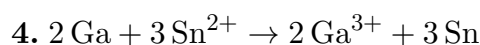
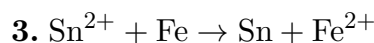
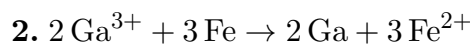
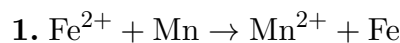

013 10.0 points

In a working electrochemical cell (+ cell voltage), the cations in the salt bridge move toward the cathode.

1. True

2. False

014 10.0 points

For the cell diagram

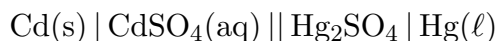

what reaction occurs at the cathode?

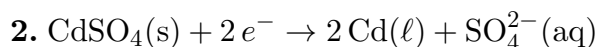
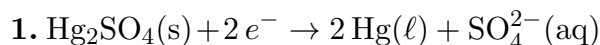

015 10.0 points

What is the cathode in

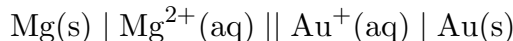

and what is the cell type?

1. Not enough information is provided.

2. Mg(s); an electrolytic cell

3. Mg(s); a voltaic cell

4. Au(s); an electrolytic cell

5. Au(s); a voltaic cell

016 10.0 points

Consider the half-reactions

017 10.0 points

Find the standard emf of the given cell

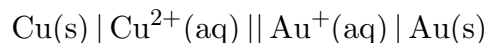
1. -0.91 V 2. -1.35 V 3. $+1.35 \text{ V}$ 4. -2.03 V 5. $+2.03 \text{ V}$ 6. $+0.91 \text{ V}$

018 10.0 points

Which species will reduce Ag^+ but not Fe^{2+} ?

1. Pt

2. Cr

3. Au

4. H_2

5. V

019 10.0 points

If the table of standard reduction potentials is ordered with the strongest reducing agents at the top, how are the reduction potentials ordered (from top to bottom)?

1. From most positive to most negative
2. From most common to least common
3. From most spontaneous to least spontaneous
4. From most negative to most positive

020 10.0 points

Which specie is the weakest reducing agent in the table of half reactions?

1. Li^+
2. F_2
3. F^-
4. Li

021 10.0 points

If the two half reactions below were used to make an electrolytic cell, what species would be consumed at the anode?

Half reaction	E°
$\text{Au}^{3+}(\text{aq}) + 3 e^- \longrightarrow \text{Au}(\text{s})$	+1.50
$\text{I}_2(\text{s}) + 2 e^- \longrightarrow 2 \text{I}^-(\text{aq})$	+0.53

1. $\text{I}^-(\text{aq})$
2. $\text{Au}(\text{s})$
3. $\text{I}_2(\text{s})$
4. $\text{Au}^{3+}(\text{aq})$